

NOTE:
OCCUPIED SEAT HEIGHT WILL BE [1.0in] 25mm LOWER THAN LISTED DIMENSION

SHOCKWAVE

PROPRIETARY AND CONFIDENTIAL

NOTICE: THIS DRAWING MAY REVEAL DESIGNS OR INFORMATION PROPRIETARY TO PROFESSIONAL COMPONENTS LTD. BY ACCEPTANCE OF REPRODUCTIONS, RECIPIENTS AGREE TO PROTECT PROFESSIONAL COMPONENTS LTD. RIGHTS AND ARE WARNED AGAINST USE OF THE DOCUMENT FOR ANY PURPOSE OTHER THAN THAT FOR WHICH IT WAS ISSUED.

SW-07823

S5 Sentinel Module

WEIGHT: [27.5 lbs] 12.5 kg

SCALE:1:24

SHEET 1 OF 1

REV: 00

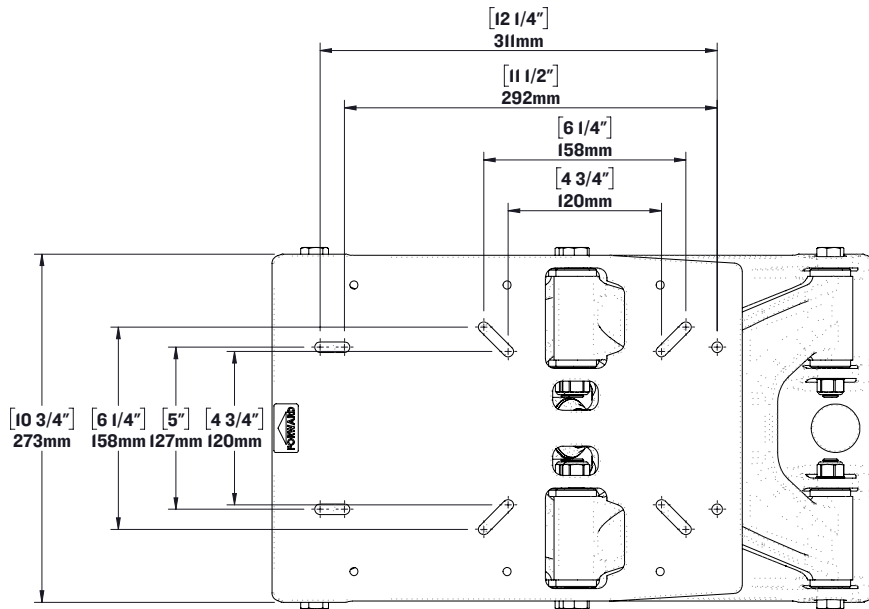
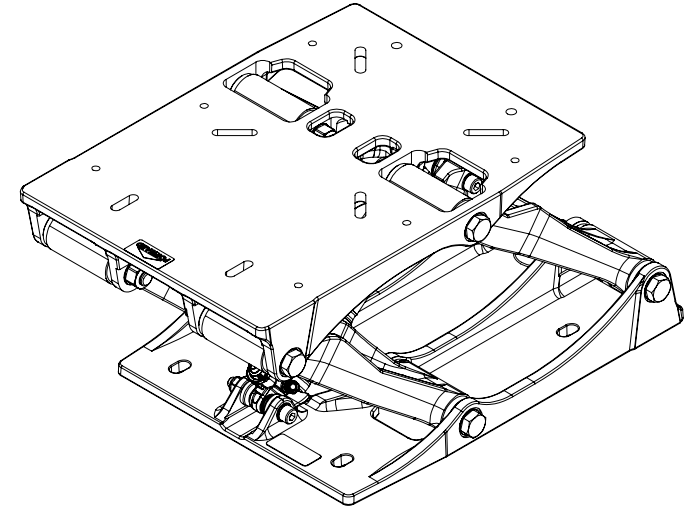
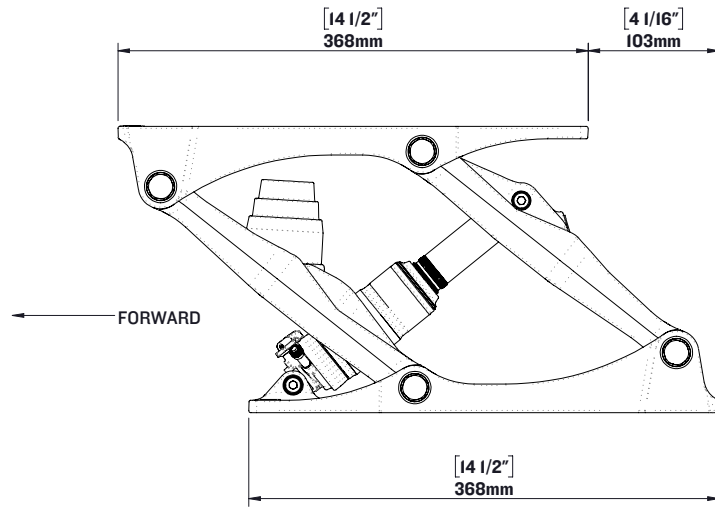

TOP

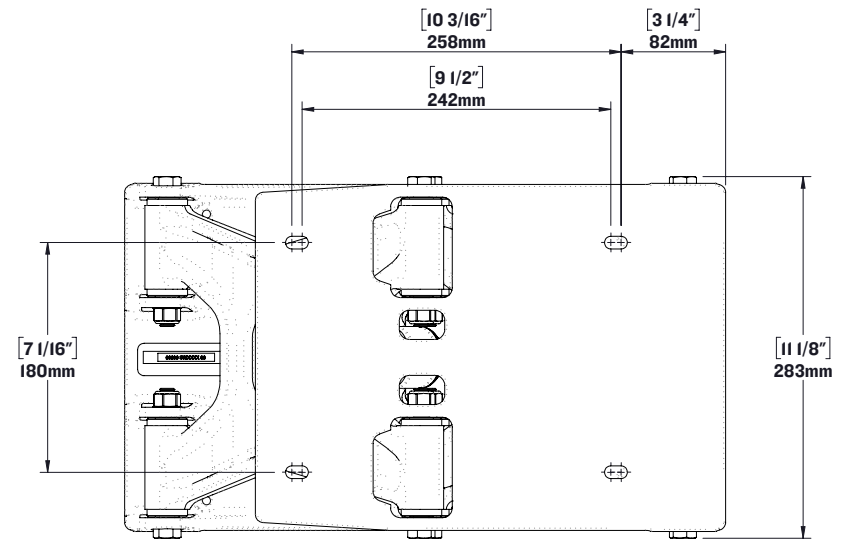

BOTTOM

NOTES:

1. ALL DIMENSIONED HOLES & SLOTS ARE 5/16"

SHOCKWAVE

PROPRIETARY AND CONFIDENTIAL

NOTICE: THIS DRAWING MAY REVEAL DESIGNS OR INFORMATION PROPRIETARY TO PROFESSIONAL COMPONENTS LTD. BY ACCEPTANCE OF REPRODUCTIONS, RECIPIENTS AGREE TO PROTECT PROFESSIONAL COMPONENTS LTD. RIGHTS AND ARE WARNED AGAINST USE OF THE DOCUMENT FOR ANY PURPOSE OTHER THAN THAT FOR WHICH IT WAS ISSUED.

SW-07823

S5 Sentinel Module

WEIGHT: [26.46 lbs] 12 kg

SCALE: 1:6

SHEET 1 OF 1

REV: 00